

IFBBEV SET-UP SHEET

NAME: _____
 DATE: _____
 TRACK: _____
 EVENT: _____

TRACK			
TRACK SIZE	<input type="checkbox"/> SMALL	<input type="checkbox"/> MEDIUM	<input type="checkbox"/> LARGE
GRIP LEVEL	<input type="checkbox"/> LOW	<input type="checkbox"/> MEDIUM	<input type="checkbox"/> HIGH
TRACK CONDITION	<input type="checkbox"/> SMOOTH	<input type="checkbox"/> GROOVED	<input type="checkbox"/> BUMPY
	<input type="checkbox"/> WET	<input type="checkbox"/> DUSTY	<input type="checkbox"/> LOAMY

COMMENTS

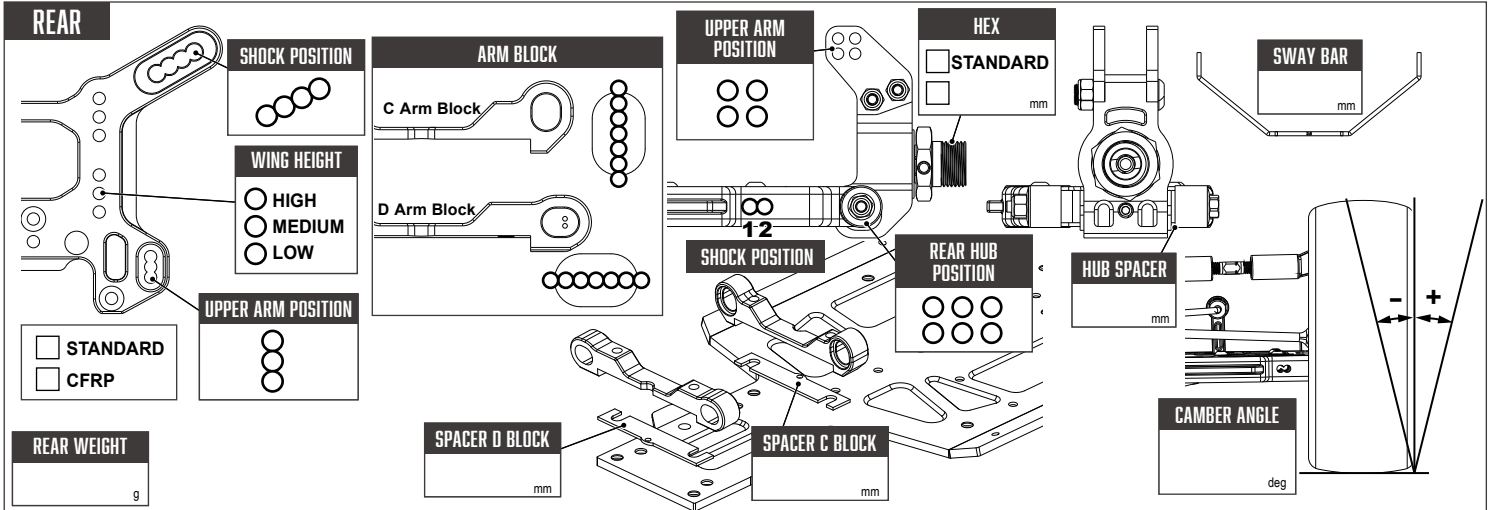
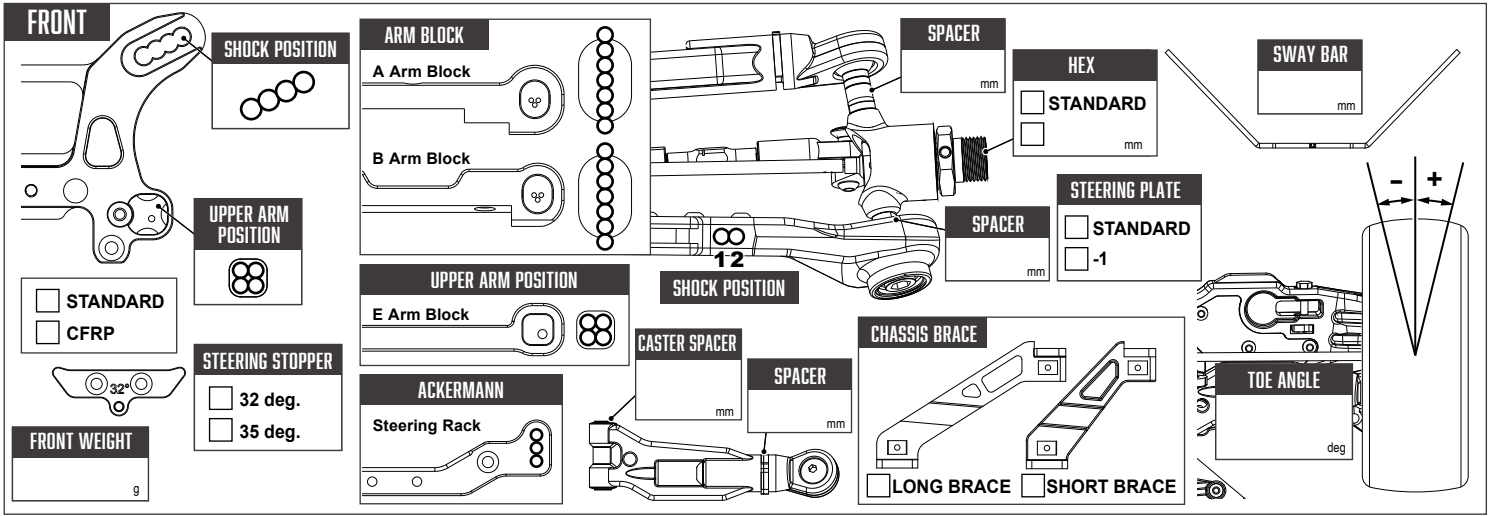

FRONT	SHOCKS	REAR
	OIL	
	SPRING	
	PISTON HOLES	
	MEMBRANE	
	EMULSION	

NOTES:

FRONT	DIFFS OIL GRADE	REAR
	CENTER	

NOTES:

GEARING	
PINION GEAR:	SPUR GEAR:

ELECTRONICS
MOTOR:
ESC:
BATTERY TYPE:
NOTES:

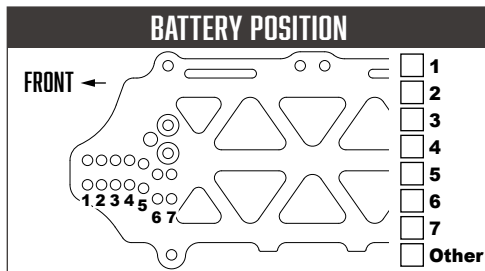
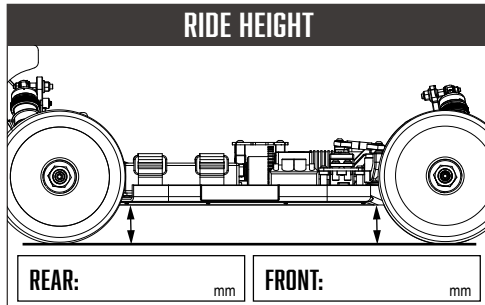

BODY & WING
BODY:
WING:
NOTES:

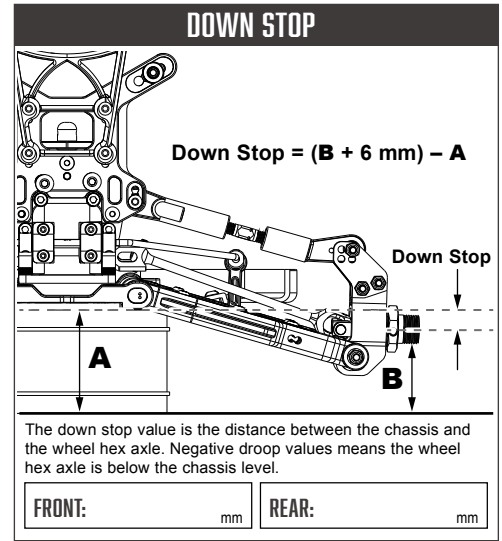

TIRES
TIRE:
INSERT:
WHEEL:
NOTES: